

CKK7481J-0.7-21B-VM

标记 MARK	ECN	修改内容 REVISIONS	签名 DWN.	日期 DATE

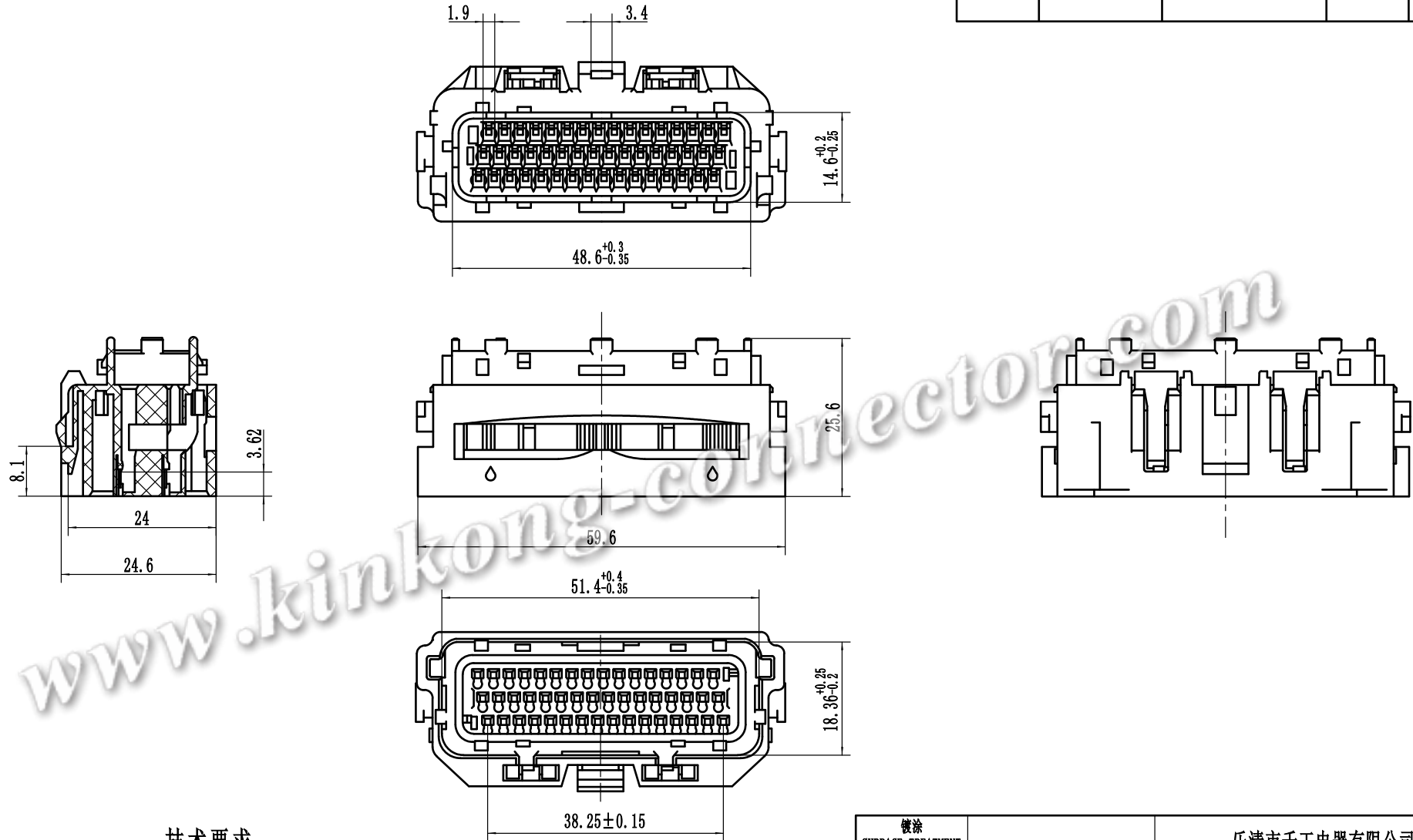

NOTES

1. The sharp Angle is blunt.
2. No tolerance shall conform to the requirements of GB/T14486-2008-MT6.
3. On the machining surface of parts, there should be no scratches, scrapes and other damage parts surface defects.

技术要求

1. 锐角倒钝。
2. 未注公差应符合 GB/14486-2008-MT6。
3. 零件加工表面上, 不应有划痕、擦伤等损伤零件表面的缺陷。

未注尺寸公差表 NO. TOLERANCES GB/14486-2008-MT6			
尺寸范围 DIM. RANGE	尺寸公差 DIM. TOLERANCES	尺寸范围 DIM. RANGE	尺寸公差 DIM. TOLERANCES
0~3	±0.23	>14~18	±0.36
>3~6	±0.26	>18~24	±0.40
>6~10	±0.29	>24~30	±0.45
>10~14	±0.33	>30~40	±0.50

镀涂 SURFACE TREATMENT		乐清市千工电器有限公司 YUQING KINKONG ELECTRIC CO., LTD.				
产品材料 MATERIAL	PBT					
产品名称 NAME	主体 MAIN BODY	设计 DRAWN BY	审核 CONFIRMED BY	批准 APPROVED BY		
物料编号 PART NO.						
产品型号 TYPE	CKK7481J-0.7-21B-VM					
客户型号 ARTICLE NO.		版次 REV.	第一视角 1st-PERSON VIEW	比例 FREE	单位 UNIT	页数 PAGE
重量 WEIGHT		1.0		1.5:1	mm	1/1